



Thermo Scientific Xpert C600 X-Ray Inspection System

- Detects foreign objects
- Verifies product integrity
- High power for large packages

high performance

inspection to protect your brand

The Thermo Scientific Xpert C600 x-ray system offers a wide and tall aperture for larger products such as cases, bags and trays. It is ideally suited for end of line inspection and comes standard all the same industry leading capabilities as other Xpert models.

Thermo
SCIENTIFIC

Thermo Scientific Xpert™ C600 X-Ray Inspection System

Application and X-Ray Specifications

X-Ray Power	80 kV, 2 mA (160W)
Detector Scan Rate	Up to 2800 lines/second
Detector Resolution	0.8mm only
Detection Algorithms Available	Binary, Contrast, Gradient, Groups, Morphology
Inspection Algorithms Available	Weight, Count, Grid and customizations
Aperture Width and Height	See beam coverage drawing
Belt Speed Range	10 m/min to 80 m/min (33 ft/min to 263 ft/min)
Multilane Operation	Up to 8 lanes
Conveyor Heights Available	800 mm to 1400 mm (31.5 in to 55 in)
Conveyor Lengths Available	1.4 m (4.6 ft) standard, others available on request
Belt Material	FDA approved urethane
X-Ray Curtain Material	Proprietary no-lead material
Safety/Security Features	X-ray power key, emergency stops, radiation curtains, LED X-ray imminent/on lights, all doors equipped with magnetic interlocks
Human Machine Interface (HMI)	15-inch diagonal touchscreen with protective cover
Interface Languages Available	English, Spanish, Italian, French, German, Chinese; Others available on request

Environmental, Electrical and Operational Specifications

Operating Temperature	+5°C to +40°C (+41°F to +104°F)
Machine Cooling	Built-in 2083 BTU (610 W) cabinet airconditioner
Relative Humidity	20% to 90% non-condensing
Electrical Input	190 to 240 VAC, 50/60 Hz, 20-amp service
Digital Outputs	4 available
Digital Inputs	6 available
USB Port	2.0, watertight port on outside of machine
Network Port	Ethernet
Compressed Air (for rejection devices)	80 psi to 100 psi (5.5 bar to 6.9 bar)
Machine Weight (standard model)	500 kg (1102 lbs)

Conformance Tests and Certifications

Radiation Safety Conformance	FDA CFR 21 part 1020.40, UK IRR 1999, RED act (contact factory for other regional certifications)
Export/Safety	CE, UL or CSA 508A on request (verified by ETL)
Intrusion Protection Rating	IP 54 or IP65

Thermo Scientific Xpert C600 X-Ray Inspection System Dimensions

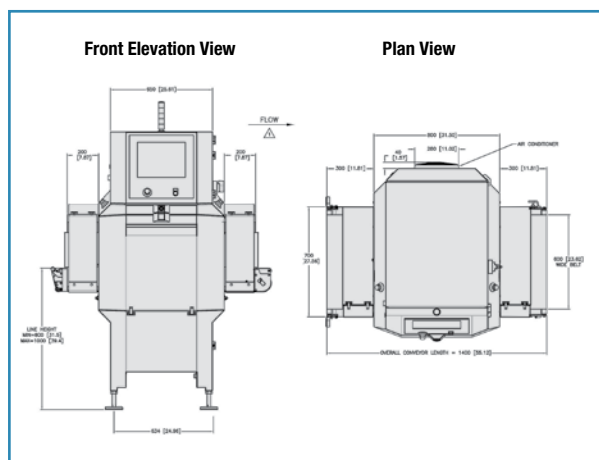

X-Ray Inspection System Beam Geometry

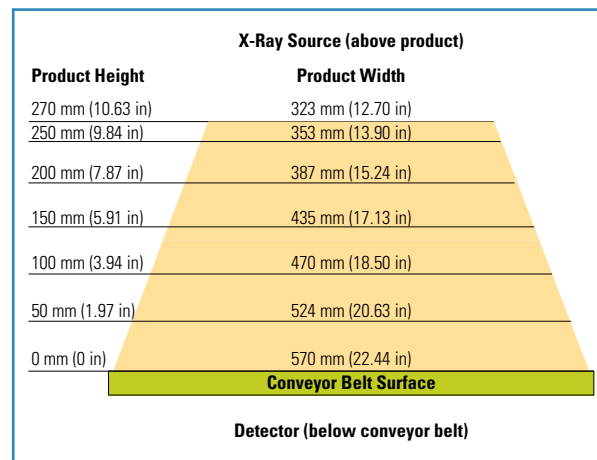

thermoscientific.com/Xpert

© 2013 Thermo Fisher Scientific Inc. All rights reserved. All trademarks are the property of Thermo Fisher Scientific Inc. and its subsidiaries. Specifications, terms and pricing are subject to change. Not all products are available in all countries. Please consult your local sales representative for details.

US and Canada 800 227 8891
Asia/Australia 800 445 3503
Mexico +52 55 5639 2184
Argentina +54 11 4334 3827
Chile +56 22 2378 5080

India +91 22 4157 8800
Italy +39 0 5217 8861
France +33 (0) 16 092 4800
Germany +49 (0) 20 882 4930
Spain +34 (0) 91 484 5965

UK +44 (0) 17 8882 0300
Netherlands +31 (0) 76 579 5555
South Africa +27 11 776 0000
China 800 810 5118

Email: sales.packaging.us@thermofisher.com

Literature Code PI.0103.0114

Thermo
 S C I E N T I F I C
 Part of Thermo Fisher Scientific